

**CHILL<sup>®</sup>**

***We Rent, Store, Sample & Move***



# “We Rent, Store, Sample & Move”

## Electronic Product Specification Brochures

**COOL ACCESSORIES**

**Totally Chill out!**

CHILL's range of promotional accessories are second to none. Whether you are sampling your product in the heat of summer or just need to keep things nice and cold, Chill has you covered with industry leading equipment.

**Cooler Bags**  
The Chill range of cooler bags are made from high quality, heavy duty, tear resistant material. They are available in a range of sizes and colors to suit your needs. They are perfect for keeping your drinks and food cool during your next outdoor event.

**Chill Bin Boxes**  
The Chill Bin Boxes are made from high quality, heavy duty, tear resistant material. They are available in a range of sizes and colors to suit your needs. They are perfect for keeping your drinks and food cool during your next outdoor event.

**Cool Coolers**  
The Chill Coolers are made from high quality, heavy duty, tear resistant material. They are available in a range of sizes and colors to suit your needs. They are perfect for keeping your drinks and food cool during your next outdoor event.

1300 932 445 (000 000 0000)

[click here>>](#)

Cool Accessories

**DISPLAY CHILLER SPECIFICATION**

**Display Made Easy**

**30 Liter Counter Top Chiller**

- Ideal for counter top POS displays
- Lockable
- LED interior lights
- Conceal door
- Lightbox with branding area

**100 Liter Open Front Chiller**

- Open front display with under-shelf lighting
- Ideal for impulse or promotion
- Food safe display - splashproof style
- On casters
- Light display

**200 & 400 Liter Single Door Chiller**

- Single door design
- 2 height options
- Lightbox with branding area
- Adjustable shelving
- Lockable

**1000 Liter Double Door Chiller**

- Double door display
- Ideal for exhibitions & product displays
- Lockable
- On casters

1300 932 445 (000 000 0000)

[click here>>](#)

Display Chiller Specification

**FREEZER SPECIFICATION**

**Freeze with Ease**

CHILL has a freezer for every need, from film shoots to events or for seasonal use during peak periods when extra frozen storage space is required. Most models can also be branded with decals for promotional use.

**Large Bar Trailer**

- Large capacity
- Heavy duty construction
- Interior shelving
- Interior lighting
- Interior shelving
- Interior lighting

**200 Liter Small**

- High capacity for easy access
- Interior shelving
- Interior lighting
- Interior shelving
- Interior lighting

**100 Liter Medium Chest**

- Interior shelving
- Interior lighting
- Interior shelving
- Interior lighting

**100 Liter Medium Sectional Chest**

- Interior shelving
- Interior lighting
- Interior shelving
- Interior lighting

**100 Liter Large**

- High capacity for easy access
- Interior shelving
- Interior lighting
- Interior shelving
- Interior lighting

**400 Liter Single Door Display**

- Interior shelving
- Interior lighting
- Interior shelving
- Interior lighting

**1000 Liter Double Door Display**

- Interior shelving
- Interior lighting
- Interior shelving
- Interior lighting

1300 932 445 (000 000 0000)

[click here>>](#)

Freezer Specification

**EUROENGELO MOBILE COOLER BOX**

**A cool transport solution**

Euroengel F2030/NDN professional mobile cooler box is engineered to perfection. This innovative refrigerated transport solution is ideal for professionals who have to move perishable goods or foodstuffs over long distances with food hygiene standards. One of the art of mobile refrigeration, versatile and heavy duty features makes it ideal for catering, food stores, event catering etc. The development of the military also applies to the versatility and robustness of this refrigerated product.

**Features**

- 1000 litre capacity
- 1200 litre capacity
- 1500 litre capacity
- 2000 litre capacity
- 2500 litre capacity
- 3000 litre capacity
- 3500 litre capacity
- 4000 litre capacity
- 4500 litre capacity
- 5000 litre capacity
- 5500 litre capacity
- 6000 litre capacity
- 6500 litre capacity
- 7000 litre capacity
- 7500 litre capacity
- 8000 litre capacity
- 8500 litre capacity
- 9000 litre capacity
- 9500 litre capacity
- 10000 litre capacity

**Specifications**

1300 932 445 (000 000 0000)

[click here>>](#)

Euroengel Mobile Cooler Box

**MOBILE COOLROOM SPECIFICATION**

**Small Chill Room**

The Small Chill Room is the perfect carry fridge for small functions, film shoots, market days and events with less than 30 people.

**Benefits**

- 1000 litre capacity
- 1200 litre capacity
- 1500 litre capacity
- 2000 litre capacity
- 2500 litre capacity
- 3000 litre capacity
- 3500 litre capacity
- 4000 litre capacity
- 4500 litre capacity
- 5000 litre capacity
- 5500 litre capacity
- 6000 litre capacity
- 6500 litre capacity
- 7000 litre capacity
- 7500 litre capacity
- 8000 litre capacity
- 8500 litre capacity
- 9000 litre capacity
- 9500 litre capacity
- 10000 litre capacity

**Mobile Cool Room Specifications**

1300 932 445 (000 000 0000)

[click here>>](#)

Small Cool Room Specification

**MOBILE COOLROOM SPECIFICATION**

**Large Chill Room**

For football and event cold storage you can't get just the Large Chill Room. For weddings, parties, festivals, catering, fairs and functions with 100+ guests.

**Benefits**

- 1000 litre capacity
- 1200 litre capacity
- 1500 litre capacity
- 2000 litre capacity
- 2500 litre capacity
- 3000 litre capacity
- 3500 litre capacity
- 4000 litre capacity
- 4500 litre capacity
- 5000 litre capacity
- 5500 litre capacity
- 6000 litre capacity
- 6500 litre capacity
- 7000 litre capacity
- 7500 litre capacity
- 8000 litre capacity
- 8500 litre capacity
- 9000 litre capacity
- 9500 litre capacity
- 10000 litre capacity

**Mobile Cool Room Specifications**

1300 932 445 (000 000 0000)

[click here>>](#)

Large Cool Room Specification

**REFRIGERATED VAN RENTAL**

**Take the Transit Lane**

The Chill Transit Van allows the city. Easy to drive & park for cold & frozen transportation & effortlessly becoming a mobile advancement for promotional branding & product launches.

**Benefits**

- 1000 litre capacity
- 1200 litre capacity
- 1500 litre capacity
- 2000 litre capacity
- 2500 litre capacity
- 3000 litre capacity
- 3500 litre capacity
- 4000 litre capacity
- 4500 litre capacity
- 5000 litre capacity
- 5500 litre capacity
- 6000 litre capacity
- 6500 litre capacity
- 7000 litre capacity
- 7500 litre capacity
- 8000 litre capacity
- 8500 litre capacity
- 9000 litre capacity
- 9500 litre capacity
- 10000 litre capacity

**Chill Refrigerated Van Specifications**

1300 932 445 (000 000 0000)

[click here>>](#)

Refrigerated Van Rental

**SKID PALLET ROOM SPECIFICATIONS**

**Contemporary Containers**

CHILL Skid Rooms combine unique form with smart function, a dynamic alternative to bulky energy draining containers. Ideal for markets, trade fairs, seminars, construction/retailing sites & event catering.

**Benefits**

- 1000 litre capacity
- 1200 litre capacity
- 1500 litre capacity
- 2000 litre capacity
- 2500 litre capacity
- 3000 litre capacity
- 3500 litre capacity
- 4000 litre capacity
- 4500 litre capacity
- 5000 litre capacity
- 5500 litre capacity
- 6000 litre capacity
- 6500 litre capacity
- 7000 litre capacity
- 7500 litre capacity
- 8000 litre capacity
- 8500 litre capacity
- 9000 litre capacity
- 9500 litre capacity
- 10000 litre capacity

**4 Pallet Skid**

**2 Pallet Skid**

**Skid Room Specifications**

1300 932 445 (000 000 0000)

[click here>>](#)

Skid Room Pallet Specification



## Totally Chill Out!

Chill's range of promotional accessories are second to none. Whether you are sampling your product in the heat of summer or just need to keep things nice and cold, Chill has you covered with industry leading equipment.



### Cooler Bags

The Cooler Bag allows safe storage of hot food, drinks or ice-cream and maintains a constant temperature. Strong yet lightweight, it uses the same highly effective insulating material that was developed for the Space Program.



#### Features

- Worn comfortably over the shoulders
- Easy entry and re-load of product
- Handy velcro closure
- Display your product or brand in the A5 pocket

	External	Internal
Width	490 mm	540 mm
Height	220 mm	280 mm
Depth	380 mm	500 mm

<b>Logo Pouch</b>	A5 (150 x 240mm) with clear face
<b>Main Access</b>	Full circumference zip (1000mm) top entry
<b>Quick Access</b>	Hinged top flap with velcro closure (250 x 220mm)
<b>Colour</b>	White with black trim
<b>Outer Skin</b>	PVC/nylon
<b>Inner Skin</b>	Glass fabric with laminated aluminum sprayed polyester film (460g/m <sup>2</sup> )
<b>Lining Infill</b>	Glass needle matt, 10mm thickness x 100 kg/m <sup>3</sup> density
<b>Shoulder Straps</b>	Slide adjustable Nylon with crossover back design

### Chilli Bin Eskies

From a backyard BBQ to onsite event catering the Chilli Bin Eskey offers superior ice holding abilities ensuring the freshness and longevity of your food & beverages.



#### Features

- Keeps ice for up to 5 days
- High grade UV resistant polyethylene mobile & lightweight
- Available in 40 or 150L models
- Unique quad latch system
- Mobile & light weight

40 Litre	Lid	Base
Width	430 mm	360 mm
Length	570 mm	480 mm
Height	380 mm	

150 Litre	Lid	Base
Width	570 mm	500 mm
Length	830 mm	760 mm
Height	610 mm	

<b>Capacity</b>	40 - 150 Litre capacities available
<b>Main Access</b>	Hinged top lid
<b>Closure</b>	High quality fold lock
<b>Seals</b>	Air tight rubber seal
<b>Materials</b>	A-grade U.V stabilised Polyethylene
<b>Insulation</b>	High pressure injected foam polyurethane in base and lid
<b>Thermodynamics</b>	Unbelievable temperature retention - up to 5 day ice preserve

### Opti Coolers

These Opticooler units for your next sampling or promotional event can be custom branded/wrapped with your logo. Used either as a static or portable beverage vending unit, the places you can take the Opticooler are vast.



The Opticooler unit also features a detachable lid - perfect for those hot outdoor events! With a well-insulated barrel the Opticooler keeps beverages icy cold.

Width	530 mm
Height	875 mm
Depth	1665 mm

<b>Capacity</b>	84 cans or 60 x 600ml bottles (less with ice)
<b>Main Access</b>	Removable hinged clear top lid
<b>Materials</b>	Molded pasltic barrel
<b>Mobility</b>	Twin wheel rear axle - tilt and roll with waist height handle
<b>Thermodynamics</b>	Excellent retention for all day use
<b>Drainage</b>	Manually controlled internal drainage system
<b>Branding</b>	Total cylindrical surface can be wrapped in full colour graphic decal
<b>Accessories</b>	Umbrella & click in display/tables additional

# DISPLAY CHILLER SPECIFICATION

## Display Made Easy

### 80 Litre Counter Top Chiller

- Ideal for counter top/POS displays
- Lockable
- LED interior lights
- Curved door
- Lightbox with branding area

Width	425 mm	Temp Range	+1°C to +10°C
Depth	404 mm	Shelves	4 incl base
Height	980 mm	Branding Area	425w x 180h
Weight	36 kg	Power	164 watts



### 900 Litre Open Front Chiller

- Open front display with undershelf lighting
- Ideal for impulse or promotion
- Food safe display - grab'n'go style
- On casters
- Night blind

Width	900 mm	Temp Range	+0°C to +3°C
Depth	575 mm	Shelves	5 incl base
Height	1910 mm	Branding Area	800w x 190h
Weight	90 kg	Power	1365 watts



### 300 & 400 Litre Single Door Chiller

- Single door design
- 2 height options
- Lightbox with branding area
- Adjustable shelving
- Lockable

	300L	400L		
Width	620 mm	620 mm	Temp Range	+1°C to +10°C
Depth	655 mm	655 mm	Shelves	4 / 5 incl base
Height	1820 mm	2100 mm	Branding Area	595w x 220h
Weight	88 kg	99 kg	Power	5000 watts



### 1000 Litre Double Door Chiller

- Double door display
- Ideal for exhibitions & product displays
- Lockable
- On casters

Width	1130 mm	Temp Range	+1°C to +4°C
Depth	700 mm	Shelves	6
Height	2195 mm	Branding Area	1130w x 370h
Weight	200 kg	Power	12000 watts



All Units are single phase 240V power

## Freeze with Ease

Chill has a freezer for every need, from film shoots to events or for seasonal use during peak periods when extra frozen storage space is required. Most models can also be branded with decals for promotional use.

### Large 8m<sup>3</sup> Trailer

- Single door walk in unit
- Large 8m<sup>3</sup> capacity
- Optional shelving for food storage
- Lockable

	Internal	External		
Width	1550 mm	2330 mm	Temp Range	-10°C to -20°C
Depth	2150 mm	4250 mm	Volume	8m <sup>3</sup>
Height	1950 mm	2560 mm	Power	10 amp - (single phase 240v)
Weight	n/a			



### 220 Litre Small

- Small portable size
- Lightweight lid for easy access
- Interior light
- Ideal for minimal frozen storage



Width	746 mm	Temp Range	-15°C to -18°C
Depth	662 mm	Volume	220 Litres
Height	903 mm	Power	342 watts - (single phase 240v)
Weight	55 kg		

### 300 Litre Medium Glass

- Ideal for ice cream / frozen food display
- Curved sliding glass lids
- Integrated lock and key
- Lockable casters



Width	1009 mm	Temp Range	-14°C to -24°C
Depth	615 mm	Volume	300 Litres
Height	949 mm	Power	220 watts - (single phase 240v)
Weight	70 kg		

### 300 Litre Medium Stainless Steel

- Versatile storage capacity
- Hinged stainless steel lid
- Internal light
- Lockable casters
- Temperature display



Width	1012 mm	Temp Range	-15°C to -25°C
Depth	715 mm	Volume	300 Litres
Height	903 mm	Power	175 watts - (single phase 240v)
Weight	65 kg		

### 700 Litre Large

- Maximum storage capacity
- Hinged stainless steel lid
- Internal light
- Lockable casters
- Temperature display



Width	2055 mm	Temp Range	-15°C to -25°C
Depth	715 mm	Volume	700 Litres
Height	903 mm	Power	425 watts - (single phase 240v)
Weight	107 kg		

### 400 Litre Single Door Display

- Designed for merchandising & high visual product display
- Lightbox
- Lockable



Width	698 mm
Depth	640 mm
Height	1986 mm
Weight	100 kg
Temp Range	-15°C to -18°C
Volume	400 Litres
Power	10 amp - (single phase 240v)

### 1000 Litre Double Door Display

- Ideal for premium food display
- Optional lightbox
- Adjustable shelving
- Lockable



Width	1130 mm
Depth	700 mm
Height	2195 mm
Weight	283 kg
Temp Range	-15°C to -21°C
Volume	1000 Litres
Power	15 amp - (single phase 240v)

# EUROENGEL MOBILE COOLER BOX

## A cool transport solution

Euroengel F0330/NDN professional mobile cooler box is engineered to perfection

This innovative refrigerated transport solution is ideal for professionals who have to move perishable goods on board standard cars or vans in accordance with food hygiene standards. State of the art in mobile refrigeration, versatile and heavy duty features makes it ideal for caterers, food stylists, & even camping trips. Their deployment in the military also testifies to the versatility and robustness of this refrigerated product.

### Features

- State of the art Italian design
- 330L capacity
- Powered by 12-24v (standard car socket) or into mains 100-240v when stationary
- Heavy duty, robust military grade engineering
- Digital temperature controller with readout
- Hygienic, food safe & easy to clean to standard HACCP/(93/43/EEC)
- Environmentally friendly CFC free R134a refrigerant gas



**Euroengel**  
 Professional mobile refrigeration

  
 ICR  
 THE WAY WE BELIEVED TO BE

### Euroengel Mobile Cooler Box



Legendary Mobility



Bullet Proof  
 Durability\*

\*F0330/NDN model shown

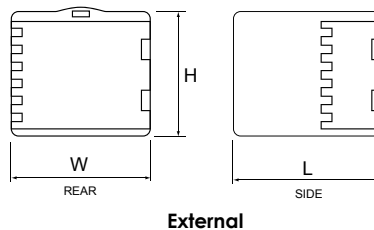
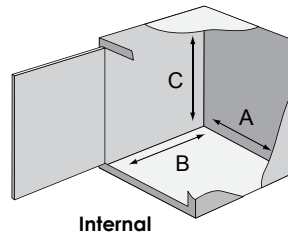

### Euroengel Specification

		Internal	External
A	Width	610 mm	-
B	Depth	660 mm	-
C	Height	810 mm	-
L	Length	-	1000 mm
W	Width	-	910 mm
H	Height	-	1020 mm
Weight		90 Kg	
Volume		330 litre	
Power		12-24v DC & 100-240v AC	
Thermostat		Digital	
Temperature		down to +0°C	

<b>Design</b>	Italian made and engineered
<b>Main Access</b>	Hinged front door
<b>Closure</b>	Large molded plastic clips
<b>Seals</b>	Air tight rubber seal
<b>Materials</b>	High quality polyethylene
<b>Insulation</b>	Injected foam insulation
<b>Thermodynamics</b>	Electronic temperature control via externally mounted panel
<b>Hygiene</b>	Full HACCAP compliance



Convenient Digital Control

# MOBILE COOLROOM SPECIFICATION

## Small Chill Room

The Small Chill Room is the perfect party fridge for small functions, film shoots, market days and events with less than 30 people.

### Benefits

- Versatile & portable
- Any location Australia wide
- Delivered & picked up by our experienced staff - OH&S accredited
- Near new 'food safe' equipment - independently assessed
- Pressure cleaned & checked after each use

### Features

- 3 cubic M capacity (15-30 cases)
- 0-8 C° temperature range
- Single door reach in/step in unit
- Shelving for food storage
- Lockable



Small internal shelving

### Small Mobile Cool Room

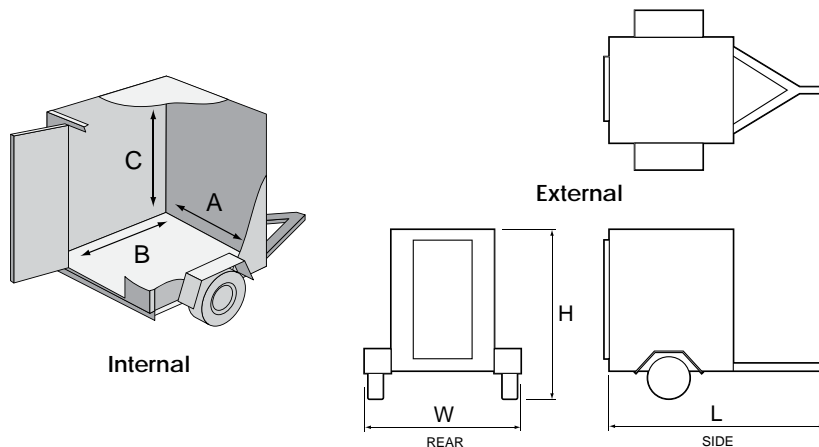

### Mobile Cool Room Specification

	Internal	External
A	Width	1050 mm
B	Depth	1360 mm
C	Height	1350 mm
L	Length	2980 mm
W	Width	1690 mm
H	Height	1970 mm
Power	240v/Single Phase 10 Amp	
Temperature	0°c to +8°c	
Capacity	3 cubic metres - approx 15-30 cases	

All models are provided with 20m tagged and tested extension lead and exterior trailer lock. Entry door can be secured with a padlock (not supplied).



# MOBILE COOLROOM SPECIFICATION

## Large Chill Room

For Festival and Event cold storage you can't go past the large Chill room. For weddings, parties, florists, caterers, fetes and functions with 100+ guests.

### Benefits

- Versatile & portable
- Any location Australia wide
- Delivered & picked up by our experienced staff- OH&S accredited
- Near new 'food safe' equipment - independently assessed
- Pressure cleaned & checked after each use

### Features

- 8 cubic M capacity (80-200 cases)
- 0-8 C° temperature range
- Single door walk in model
- Optional shelving for food storage
- Internal light
- Lockable



Optional internal shelving

### Large Mobile Cool Room

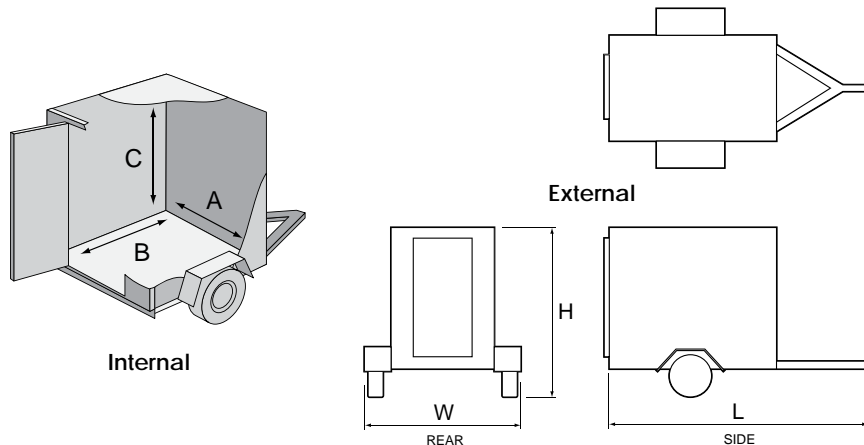

### Mobile Cool Room Specification

	Internal	External	
A	Width	1650 mm	-
B	Depth	2250 mm	-
C	Height	1950 mm	-
L	Length	-	4250 mm
W	Width	-	2330 mm
H	Height	-	2570 mm
Power	240v/Single Phase 10 Amp		
Temperature	0°c to +8°c Freezer models available		
Capacity	8 cubic metres - approx 80-200 cases		

All models are provided with 20m tagged and tested extension lead and exterior trailer lock. Entry door can be secured with a padlock (not supplied).



# REFRIDGERATED VAN RENTAL

## Take the Transit Lane

The Chill Transit Van loves the city. Easy to drive & park for cold & frozen transportation & effortlessly becoming a mobile advertisement for promotional branding & product launches.

### Benefits

- Food safe transport vehicles
- Near new rental fleet
- Short or long term rentals
- Best quality and most reliable cooling equipment on the market

### Features

- Refrigerated with freeze temperature to -20
- Electric standby for overnight/ onsite operation
- 2 pallet capacity



Optional artwork wrap for promotion



Ford Transit 2-Pallet



Rear pallet load

### The Chill Transit Van

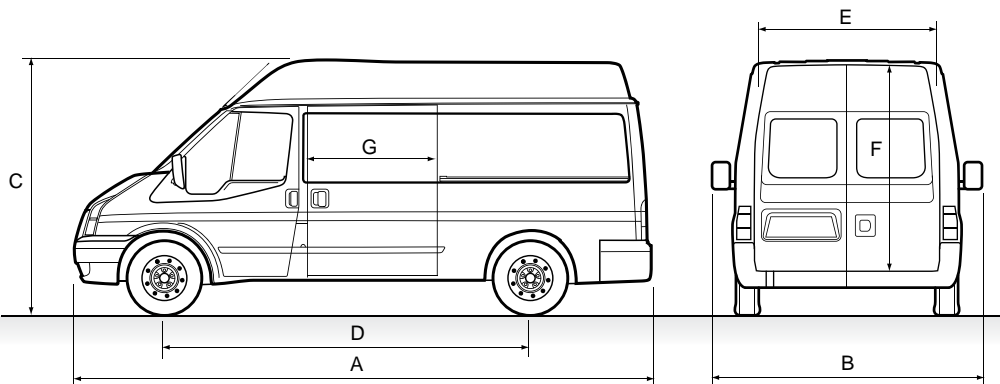

### Chill Refrigerated Van Specifications

A	Overall Length	5800 mm	<b>Inclusions</b> • 100 km/day • 240v electric standby power on all units & 15m extension lead • Fridge/freezer on all units
B	Overall Width	2374 mm	
C	Overall Height	2387 mm	
D	Wheel Base	3800 mm	
E	Rear Door Width	1625 mm	
F	Door Height	1800 mm	<b>Exclusions</b> • Diesel fuel • Windscreen, overhead/underbody damage • Toll charges and infringements
G	Side Door Width	1425 mm	
Model	Transit RWD van mid roof		<b>Optional Extras</b> • Courier trolley • Artwork wrapping • Delivery & pick up • GPS navigation • Blue tooth handsfree • Satellite tracking • Insurance excess reduction
Capacity	2 pallets / 9.85 m <sup>3</sup> / 1.2T		
Gross Mass	3.3 Tonne		
Transmission	6 speed manual		
Fuel	Diesel - (capacity 80 litres)		
Standard Power	240V single phase/15 AMP		
Temperature	+10 to -20C		

# SKID PALLET ROOM SPECIFICATIONS

## Contemporary Containers

Chill Skid Rooms combine unique form with smart function, a dynamic alternative to bulky energy draining containers.

Ideal for festivals, hotels/clubs, wineries construction/mining sites & event catering.

### Benefits

- Full pallet fork load
- Unique 2 pallet wide storage
- Energy efficient & 'Green' design
- Low rise access - minimal OH&S risk
- Food safe & pressure cleaned
- Onsite portability with standard forklift
- Short or long term rentals

### Features

- 2 Versatile sizes
- Single or double door models
- Optional shelving for catering
- Internal light
- Lockable



2 pallet wide storage



Fork lift mobility



Internal shelving



Mobile delivery

### 4 Pallet Skid

Single door model available

### 6 Pallet Skid

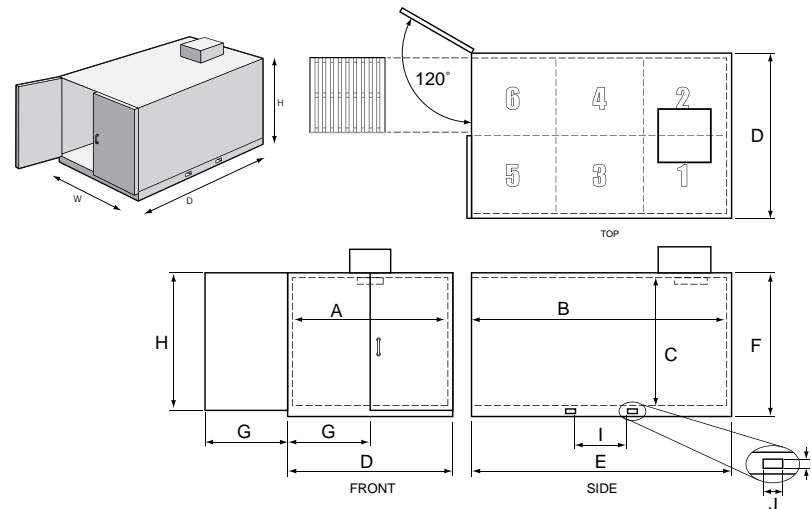
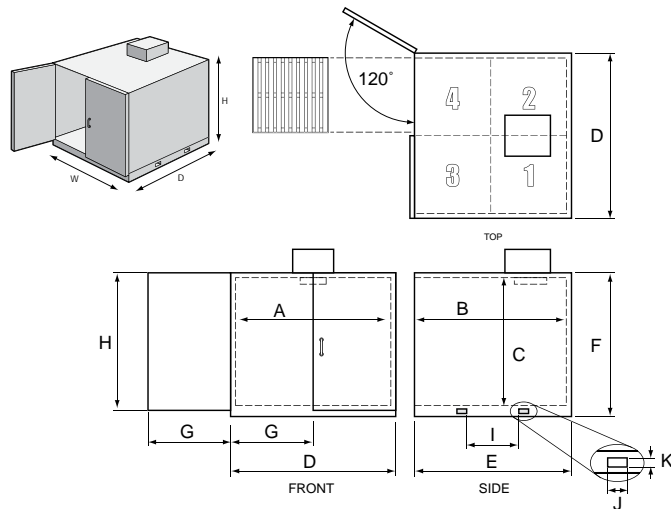

### Skid Room Specifications

	4 Pallet	6 Pallet
A	Width Internal	2380
B	Depth Internal	2430   3620
C	Height Internal	1920
D	Width External	2540
E	Depth External	2708   3900
F	Height External	2220
G	Width Door	1260
H	Height Door	1980
I	Span Forks	450
J	Width Forks	200
K	Height Forks	70
Power	10 amp	15 amp
Temperature Range	0-8C	0-8C
Internal Light	✓	✓
Lockable	✓	✓
Digital Temp Display	✓	✓
Tilt Tray Delivery	✓	✓
Capacity	12.5 cM	18.5 cM
Gross Weight	900Kg	1000Kg

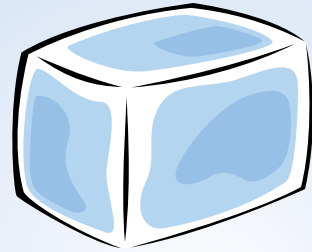

**CHILL<sup>®</sup>**

***We Rent, Store, Sample & Move***

